

# PFEIFER Button Head Fixing Bolt

## PFEIFER Recess Discs

Item-No. 05.209  
Item-No. 05.201



**PFEIFER**

Thread System  
Accessories

PFEIFER Recess Discs are used to install PFEIFER Thread Anchors recessed and wherever it is intended to lift the precast concrete unit with a Swivel Eye. Due to the Recess Disc a plain and clear contact with the pressure plate, perpendicular to the longitudinal axis of the Lifting Anchors is provided. Remaining recesses in the unit can be plugged after erection with the large external cap. The recess discs can be nailed onto wooden

formwork through its four nailing holes.

The PFEIFER Colour Code System guarantees easy and fast recognition of the system components using the plastic Recess Discs while the zinc plated steel type Recess Disc convinces with its extraordinary life-span.

To fix the Recess Discs to the formwork as well as for recessed installation of PFEIFER Thread Anchors, the PFEIFER Button Head Fixing Bolt is required. Having an external metric thread, PFEIFER Button Head Fixing Bolts can be used to fix either PFEIFER Lifting Anchors or PFEIFER Socket Dowels with metric thread.

Material PFEIFER Button Head Fixing Bolt:

Steel, zinc plated

Material PFEIFER Recess Disc (plastic):

Coloured plastic according to PFEIFER Colour Coding System

Material PFEIFER Recess Disc (steel):

Steel, zinc-plated

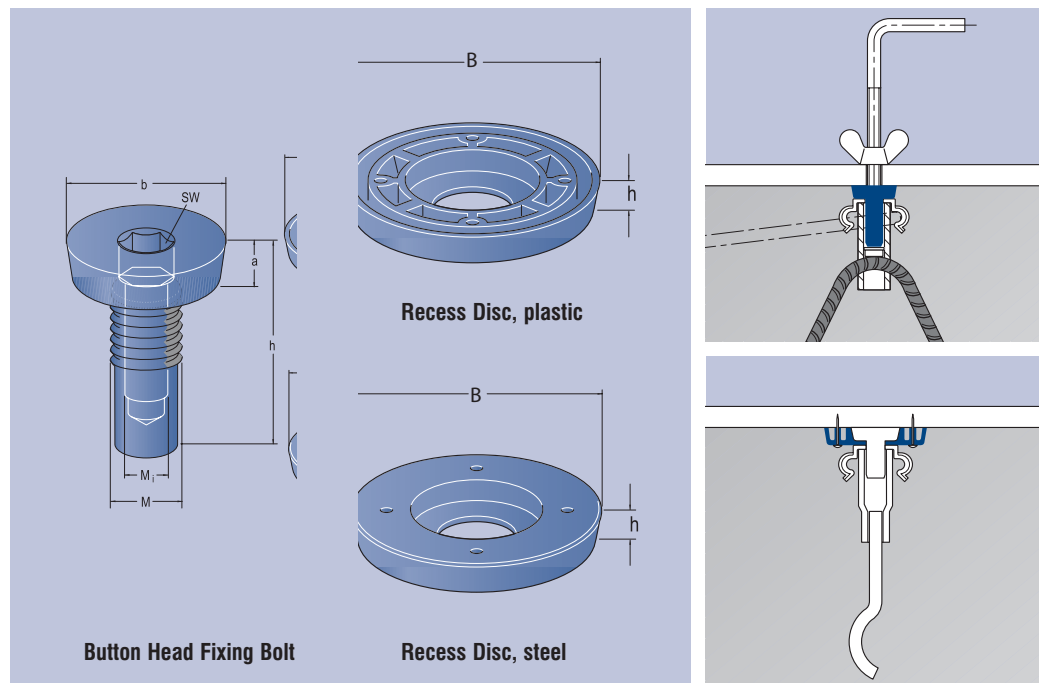

Sample order for 100 PFEIFER Recess Discs (plastic), size Rd 36: 100 PFEIFER-Recess Discs ref. no. 05.201.360

Ref. No.	Recess Disc (Plastic)			Recess Disc (Steel)		General Dimensions	
	Colour	Packing Unit Pieces	Weight approx. kg/Packing Unit	Ref. No.	Weight approx. kg/100 Pieces	Dimensions mm B	h
05.201.120	orange	50	0,46	05.201.123	11,5	50,5	10
05.201.140	white	50	0,58	05.201.143	13,5	55,5	10
05.201.160	red	50	0,63	05.201.163	16,0	59,2	10
05.201.180	pink	25	0,34	05.201.183	16,5	62,5	10
05.201.200	light-green	25	0,43	05.201.203	25,0	73,5	10
05.201.240	dark-grey	25	0,63	05.201.243	32,0	78,2	12
05.201.300	green	25	0,80	05.201.303	47,0	94,2	12
05.201.360	blue	25	1,03	05.201.363	56,0	105,2	12
05.201.420	silver-grey	25	1,55	05.201.423	80,0	115,3	15
05.201.520	yellow	25	1,68	05.201.523	110,0	135,3	15

Sample order for 50 PFEIFER Button Head Fixing Bolts, size M24 x 3 for Rd24: 50 PFEIFER-Button Head Fixing Bolts ref. no. 05.209.243

Ref. No.	Size M	Mi	Button Head Fixing Bolt Dimensions mm				SW	Weight approx. kg/100 Pieces
			b	a	h			
05.209.123	M 12 x 1,75	M 6	23,7	8,5	30,0	8	3,0	
05.209.143	M 14 x 2,0	M 8	26,7	8,5	33,5	8	5,0	
05.209.163	M 16 x 2,0	M 8	30,7	8,5	36,0	10	6,0	
05.209.183	M 18 x 2,5	M 8	33,7	8,5	42,0	10	9,0	
05.209.203	M 20 x 2,5	M 8	37,2	8,0	42,5	10	11,0	
05.209.243	M 24 x 3,0	M 10	41,2	10,0	52,5	14	17,0	
05.209.303	M 30 x 3,5	M 10	49,2	10,0	63,0	14	31,0	
05.209.363	M 36 x 4,0	M 10	59,2	10,0	74,5	14	55,0	
05.209.423	M 42 x 4,5	M 16	67,7	13,0	87,0	17	84,0	
05.209.523	M 52 x 5,0	M 16	80,7	13,0	118,0	17	172,0	

# Installation Instructions for PFEIFER Recess Disc – plastic/steel PFEIFER Fixing Bolt

For a recessed installation of the lifting anchor of the PFEIFER Thread System, the PFEIFER Recess Disc can be used together with the PFEIFER Fixing Bolt. In this way lateral additional reinforcements have a higher concrete cover.

The Recess Discs and the PFEIFER Fixing Bolts should be fixed on the formwork as shown in Fig. 1.

The lifting anchor of the PFEIFER Thread System can also be fixed tightly in the formwork with the PFEIFER Fixing Bolt. When the PFEIFER Sockets are installed with the Fixing Bolt, the important form-fit (interlocking) connection with the bent reinforcement bar is achieved as the screw presses the plastic cap tightly on to the reinforcement. The Fixing Bolt can also be used to increase the concrete cover (Fig. 2).

The plastic Recess Disc is a low-priced variation, which also offers high measure of safety through the PFEIFER Colour Code. Each size of lifting anchor has a special identifying colour which simplifies the choice of lifting anchors, lifting devices and formwork components with one another. The Recess Disc can easily be nailed on the wooden form through 2 of the 4 nail holes (Fig. 3).

If it is planned to use the PFEIFER Swivel Eye for lifting the precast concrete unit, all lifting anchors of the Thread System should be fixed in the formwork with Recess Discs and Fixing Bolts. (Fig. 4). Only in this way is it possible to achieve a bearing area for the pressure plate which is at right-angles to the longitudinal axis of the lifting anchor.

If particularly rough installation takes place the PFEIFER Steel Recess Disc is recommended as this can be used a long time because of its solid construction. The recesses can be closed attractively with the PFEIFER External Caps or the PFEIFER Screw Caps (Fig. 5).

