



JORDAHL®



JORDAHL® Anchor Channels

JTA-CE



Deutsche Kahneisen
Gesellschaft mbH

Quality since 1907

JORDAHL® anchor channels are manufactured by Deutsche Kahneisen GmbH in Germany. The history of connecting steel to concrete begins in 1907 with an invention of Julius Kahn, member of a Chicago family of architects, whose “Kahn irons” opened up completely new possibilities for construction with reinforced concrete. In 1913 Anders Jordahl, a Norwegian engineer, who introduced Kahn’s reinforcing technology in Germany, developed the Anchor Channel by designing a C-shaped profile which was used as reinforcement and connection device at the same time.

Today, with a century of experience in anchoring and connection technology “Deutsche Kahneisen GmbH” with its brand name JORDAHL® has developed into an internationally renowned company and a leader of research in anchoring technology, with a strong relationship to its customers.

JORDAHL® Products

- **Quality** made in Germany since 1907 and used in projects around the world
- **State of the art** and help customers build efficiently to maintain quality standards
- **Made under strict quality control** according to German and European approval requirements

- **Eurocode compatible** design & approved safety concept – ETA-09/0338 et al
- **Comprehensive range** of superior anchoring and connection products with accessories
- **ISO 9001:2008** based internal QA / QC processes

Whichever type of construction is in progress, JORDAHL® provides fully developed solutions in installation technology: for joining components to one another, for suspending loads or for connecting devices. Irrespective of the product application, quality and safety are fundamental to the selection of a connection system. JORDAHL® offers the following services:

- **Creative support** for planning and design
- **Customized solutions** and project-based consulting
- **Cost effective planning** and support with engineering calculations
- **Excellent technical know-how** from a team of experienced engineers
- **Reliable partnership** focusing on a long term customer relationship
- **Just in time** delivery onsite
- **Boxed per floor** on customer request



Content



Proven Anchoring ...	4	Recommended Tightening Torque T_{inst}	14
... to the Most Recent State-of-the-art	5	Corrosion Prevention	15
Overview Anchor Channel JTA-CE	6	JORDAHL® Expert Software	16
Anchor Channels JTA-CE	8	Safety of Design	18
Design Resistances of JORDAHL® T-Bolts	9	Applications	20
Design Resistances of JORDAHL® T-Bolts in stainless steel	10	Installation	22
Nuts and Washers	11	Notes	23
Pre-stressed Bolted Connections and Torque	12		

© Deutsche Kahneisen Gesellschaft mbH
All rights reserved.
We reserve the right to modifications within the framework of continued development concerning the product and application methods.

Deutsche Kahneisen Gesellschaft mbH
Nobelstraße 51
12057 Berlin

Proven Anchoring ...

For more than a century JORDAHL® anchor channels have been recognised as a secure way to anchor loads in concrete. Regardless of whether the concrete is reinforced or non-reinforced, cracked or non-cracked, JORDAHL® anchor channels always provide a load-carrying connection.

Uncomplicated Installation

- No drilling, no electrical or special tools required
- No damage to the reinforcement
- Simple compensation of building tolerances
- Rapid assembly of the anchor element:
balance – tighten the screws – finished
- No welding, no fire risk, no damage from sparks

High Safe Working Loads

- Also in cracked concrete
- Suitable for pre-stressed concrete with optimised mechanical undercut
- High serviceability, suitable for dynamic loads
- Available in 11 different profile sizes

Safety Assured

- European technical approval (ETA-09/0338)
- Suitable for assembly in the compression and tension zones
- High safe working loads also in filigree members
- Eurocode-compatible design concept
- Transparent safety concept (γ method)



Safety work



Time efficiency



Low cost



Simple to install



No risk of fire



... to the Most Recent State-of-the-art

JTA-CE

The introduction of the new European approval for JORDAHL® anchor channels JTA-CE represents the most recent state-of-the-art in anchoring in concrete.

Innovative Design Concept

Based on CEN/TS 1992-4-3

This concept is based on the European partial-load safety concept (see page 19) and the European Technical Approval for JORDAHL® anchor channels (ETA-09/0338) and leads to a generally improved utilisation of the anchor channels JTA-CE.

Optimized Design Taking into Account:

- Edge distances
- Length of the channels
- Load distribution along the channels
- Concrete strength
- Additional reinforcement
- Member thickness

JORDAHL® Expert Design Software

- Efficient engineering design in accordance with CEN/TS
- Simple and quick to use
- Input with clear 3D graphics
- Easily-comprehensible monitor output
- Testable print-out

Technical Support

We offer our assistance. Regardless of whether it is planning in the office or on the building site, our team of experienced engineers provides direct specialist support.

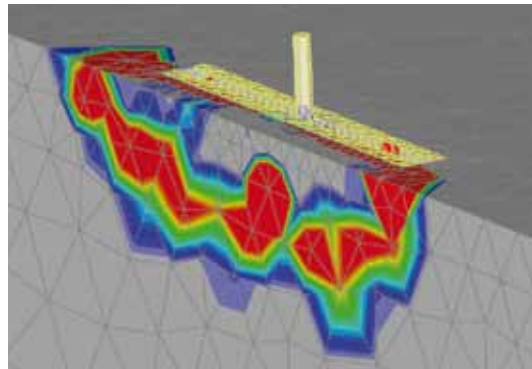

FE model

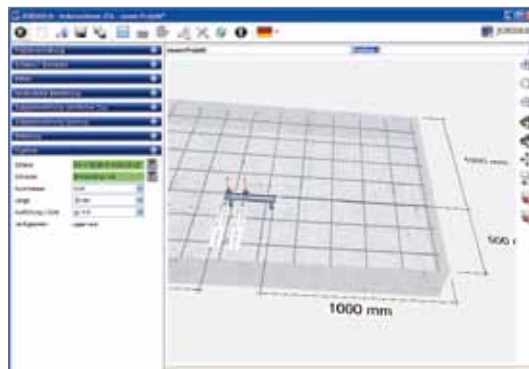

JORDAHL® Expert Software

Overview Anchor Channel JTA-CE

Hot Rolled Anchor Channels

- Material**
- Hot-dip galvanized (HDG) carbon steel
 - Stainless steel (A4)
 - Standard filler polyethylene (PE) or polystyrene (PS)

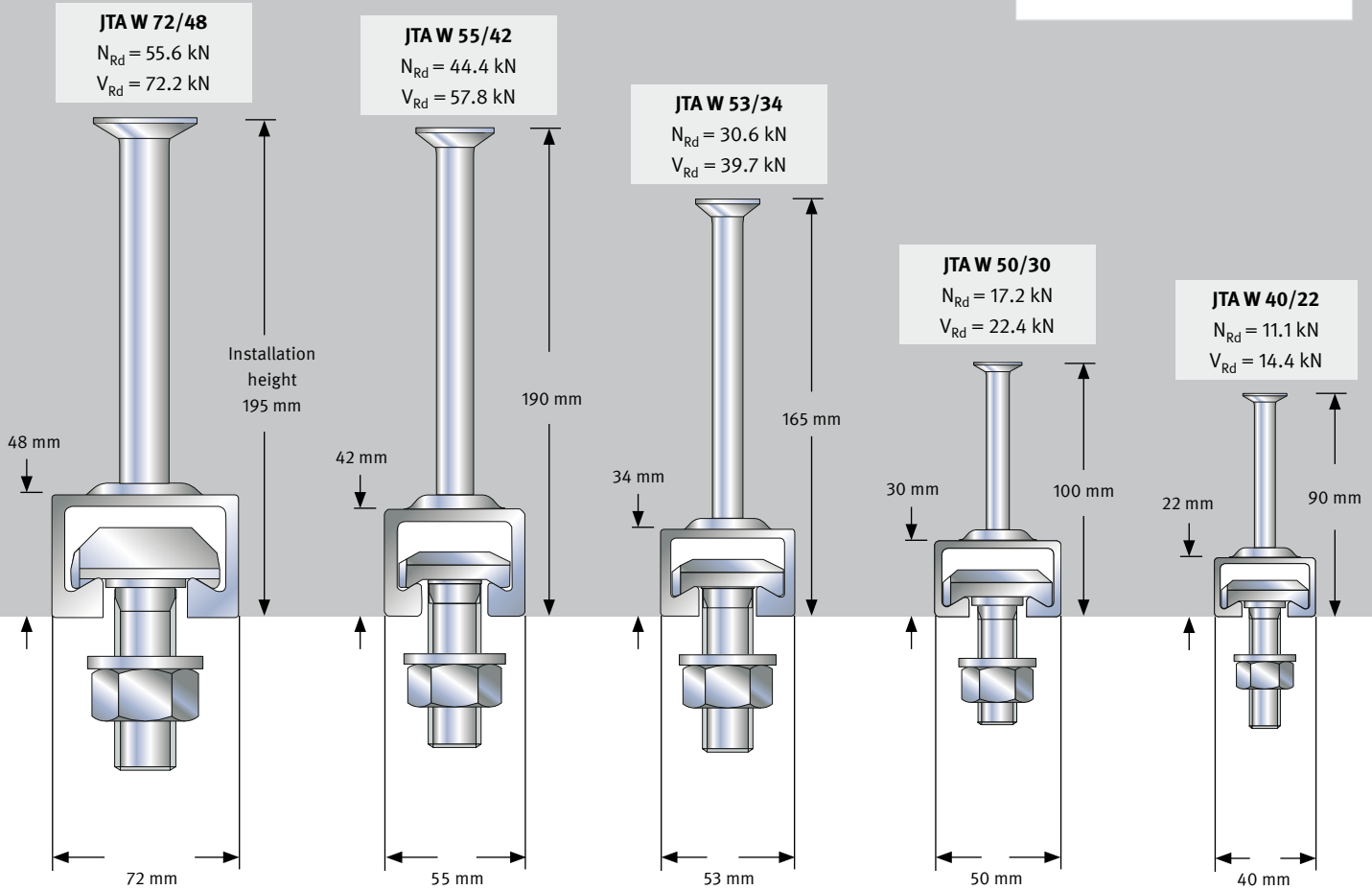

Bolts

JA	JB	JB	JB	JC
M 20	M 16	M 10	M 10	M 10
M 24	M 20	M 12	M 12	M 12
M 27	M 24*	M 16	M 16	M 16
M 30		M 20	M 20	

*JB M 24 is equivalent to JE M 24

- Material**
- Electro zinc plated (ZP) or hot-dip galvanized (HDG) carbon steel
 - Stainless steel (A4)
 - Stainless steel A4-70 available on request

Hook-head T-Bolts and Hot Rolled Profile

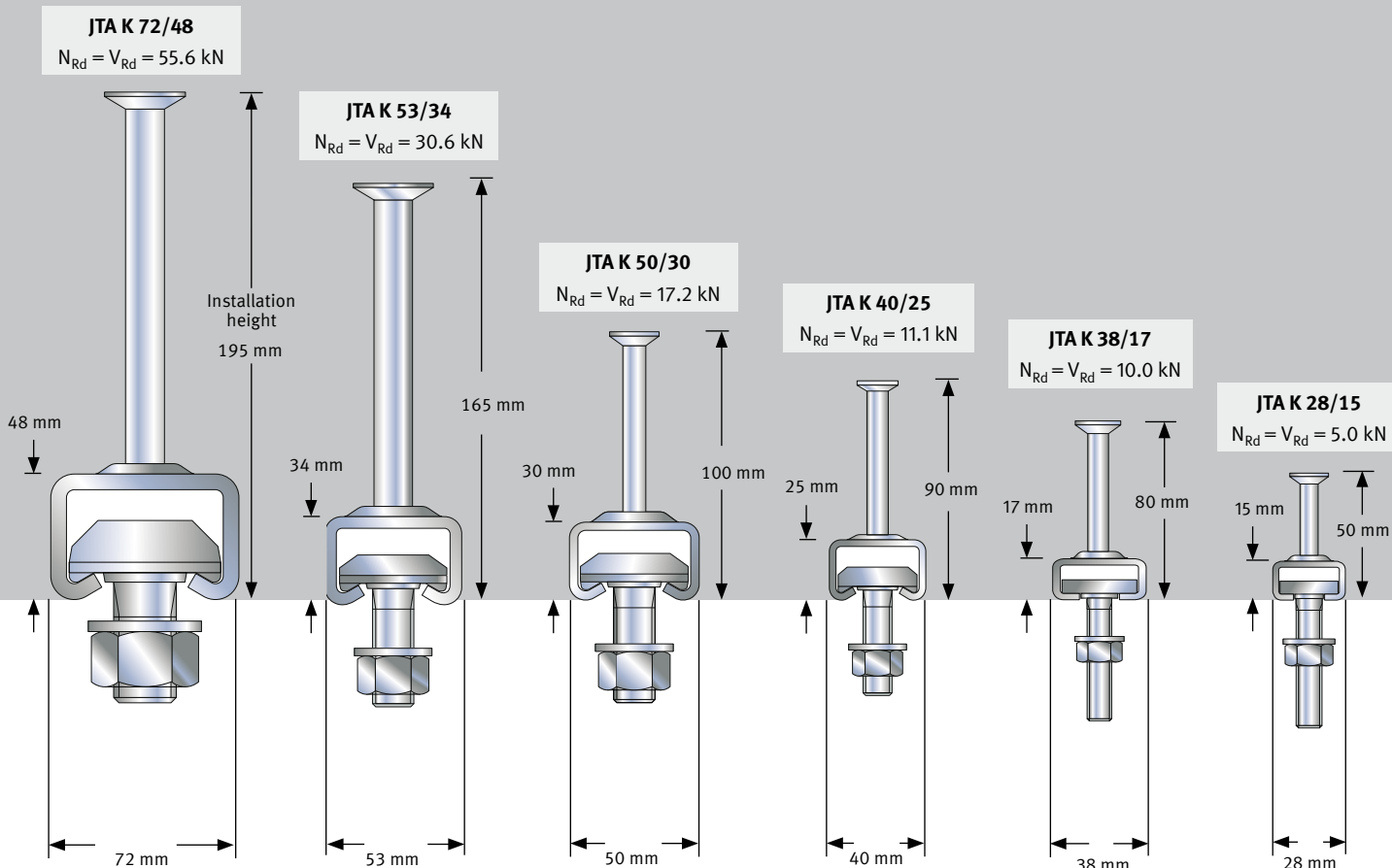

Cold Formed Anchor Channels

JA

M 20
M 24
M 27
M 30

JB

M 10
M 12
M 16
M 20

JB

M 10
M 12
M 16
M 20

JC

M 10
M 12
M 16

JH

M 10
M 12
M 16

JD

M 6
M 8
M 10
M 12

Hammer-head T-Bolts and
Cold Formed Profile

Anchor Channels JTA-CE

Features

- Optimised CE anchor channel profiles
- Increased safe working load and strengthened anchor
- Production process monitoring in accordance with ISO 9001

W-Profiles

- Hot rolled from a billet/particularly free of residual stresses
- Optimised geometry with strengthened channel lips
- Suitable for dynamic loads
- Solid lips for high tightening torques

Anchor channels made from hot rolled profiles are the preferred solution for curtain walls under high wind loads, elevators, heavy pipes under pre-stressed post-tensioned bridges, etc.

K-Profiles

- Cold-formed profiles
- Constant material strength

Cold-formed channels are used where no increased demands are required on the safe working load of the channel lips and on the operating strength.

JORDAHL® Bolts

- Hammer- or hook-head – tailored to JORDAHL® profile
- Screw quality 4.6 and 8.8 approved by building authorities
- Solid compounds by improved connections using high tightening torques

Round Anchors



These are cold forged on the backs of the channels in a monitored process. Welded anchors are also available for special applications.

Steel Grades

Most profiles are made from carbon steel material conforming to EN 10025 with a minimum yield strength of 235 N/mm². Stainless steel can be supplied for diverse corrosion-resistance grades in accordance with EN 10088.



Design Resistances of JORDAHL® T-Bolts

Bolts \varnothing		M 6	M 8	M 10	M 12	M 16	M 20	M 24	M 27	M 30	
Channel Profile	JTA	K 28/15	Hammer-head T-Bolts Type JD			–		–	–	–	–
		K 38/17	–	–	Hammer-head T-Bolts Type JH			–	–	–	
		W 40/22 K 40/25	–	–	Hook-head T-Bolts Type JC		–	–	–	–	–
		W 50/30 K 50/30	–	–	Hook-head T-Bolts Type JB			–		–	–
		W 53/34 K 53/34	–	–	Hook-head T-Bolts Type JB			–	–	–	–
		W 55/42	–	–	Hook-head T-Bolts Type JB				–	–	–
		W 72/48 K 72/48	–	–	–	–	–	Hook-head T-Bolts Type JA			
T-Bolt Strength	4.6	Tension Load N_{Rd} [kN]	4.0	7.3	11.6	16.9	31.4	49.0	70.6	91.8	112.2
		Shear Load V_{Rd} [kN]	2.9	5.3	8.4	12.1	22.6	35.3	50.7	66.0	80.6
	8.8	Tension Load N_{Rd} [kN]	–	19.5	30.9	44.9	83.7	130.7	188.3	–	–
		Shear Load V_{Rd} [kN]	–	11.7	18.6	27.0	50.2	78.4	113.0	–	–

All values are design resistances. JORDAHL® bolts are supplied electro zinc plated (ZP) or hot-dip galvanised (HDG), see page 15.

Design Resistance of JORDAHL® T-Bolts due to Bending Moments

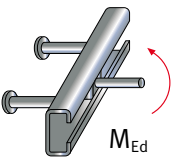
Bolts \varnothing		M 6	M 8	M 10	M 12	M 16	M 20	M 24	M 27	M 30
Max. Through-Hole in Attaching Part [mm]		7	9	12	14	18	22	26	30	33
Design Resistance Bending $M_{Rd,s}$ [Nm] 	4.6	3.8	9.0	17.9	31.4	79.8	155.4	268.9	398.7	538.7
	8.8	9.8	24.0	47.8	83.8	213.1	415.4	718.4	1065.2	1439.4

Stand-Off Installation

In the case of a stand-off installation, a connection can be stressed by a bending moment as well as by tension and shear forces. The design bending moments specified above must be taken into consideration.



Notes:

Bolt capacity may be limited by anchor channel capacity. Values are design resistances. For permissible loads divide by 1.4 safety factor.



Stand-Off Installation

Design Resistances of JORDAHL® T-Bolts in Stainless Steel

Bolts Ø		M 8	M 10	M 12	M 16	M 20	M 24	
Channel Profile	JTA	K 28/15	Hammer-head T-Bolts Type JD		–	–		–
		K 38/17	–	Hammer-head T-Bolts Type JH				–
		W 40/22 K 40/25	–	Hook-head T-Bolts Type Type JC			–	–
		W 50/30 K 50/30	–	Hook-head T-Bolts Type JB				
		W 53/34 K 53/34	–	Hook-head T-Bolts Type JB				
		W 55/42	–	Hook-head T-Bolts Type JB				
		W 72/48 K 72/48	–	–	–	–	–	Hook-head T-Bolts Type JA
T-Bolt Strength	A4-50	Tension Load N_{Rd} [kN]	–	10.1	14.8	27.4	42.8	61.7
		Shear Load V_{Rd} [kN]	–	7.3	10.6	19.8	30.9	44.5
	F4-70	Tension Load N_{Rd} [kN]	13.7	21.7	31.6	58.8	91.7	–
		Shear Load V_{Rd} [kN]	16.8	15,6	22.7	42.2	66.0	–

All values are design resistances. JORDAHL® stainless-steel bolts are preferentially manufactured from stainless steel having category of corrosion C4 (A4, L4) and C5 (F4, HC), see page 15.

Design Resistances of JORDAHL® T-Bolts due to Bending Moments

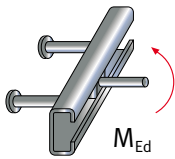
Bolts Ø		M 8	M 10	M 12	M 16	M 20	M 24	M 27	M 30
Max Through-Hole in Attaching Part [mm]		9	12	14	18	22	26	30	33
 Design Resistance Bending $M_{Rd,s}^o$ [Nm]	A4-50	7.9	15.7	27.5	70.0	136.3	235.8	–	–
	A4-70 F4-70	16.8	33.5	58.8	149.4	291.3	503.7	–	–

Stand-Off Installation

In the case of a stand-off installation, a connection can be stressed by a bending moment as well as by tension and shear forces. The design bending moments specified above must be taken into consideration.

Notes:

Bolt capacity may be limited by anchor channel capacity. Values are design resistances. For permissible loads divide by 1.4 safety factor.



Stand-Off Installation

Nuts and Washers

Hexagon Nuts to ISO 4032				
Thread	e [mm]	s [mm]	m [mm]	
M 6	11.05	10.0	5.2	
M 8	14.38	13.0	6.8	
M 10	18.90	16.0	8.4	
M 12	21.10	18.0	10.8	
M 16	26.75	24.0	14.8	
M 20	32.95	30.0	18.0	
M 24	39.55	36.0	21.5	
M 27	45.20	41.0	23.8	
M 30	50.85	46.0	25.6	

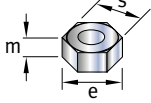

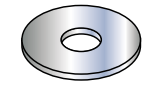
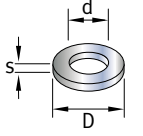
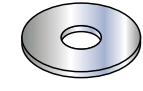
Washers ¹⁾					
	Zinc-plated Washers	Dimensions	d [mm]	D [mm]	s [mm]
	ISO 7093-1 (DIN 9021)	M 6	6.4	18.0	1.6
		M 8	8.4	24.0	2.0
		M 10	10.5	30.0	2.5
		M 12	13.0	37.0	3.0
		M 16	17.0	50.0	3.0
		M 20	22.0	60.0	4.0
		M 24	28.0	70.0	4.0
	ISO 7089 (DIN 125)	M 6	6.4	12.0	1.6
		M 8	8.4	16.0	1.6
		M 10	10.5	20.0	2.0
		M 12	13.0	24.0	2.5
		M 16	17.0	30.0	3.0
		M 20	21.0	37.0	3.0
		M 24	25.0	44.0	4.0
	ISO 7094 (DIN 440)	M 6	6.6	22.0	2.0
		M 10	11.0	34.0	3.0
		M 12	13.5	44.0	4.0
		M 16	17.5	56.0	5.0
		M 20	22.0	72.0	6.0

¹⁾ Washers for stand-off installation see following table

JORDAHL® Profile	Bolt Type	Dimensions of the Washers for Stand-off Installation							
		M 8	M 10	M 12	M 16	M 20	M 24	M 27	M 30
K 28/15	JD	ISO 7093-1	ISO 7093-1	ISO 7089	-	-	-	-	-
K 38/17	JH	-	38 x 38 x 5	ISO 7093-1	ISO 7093-1	-	-	-	-
W 40/22	JC	-	38 x 38 x 5	ISO 7093-1	ISO 7093-1	-	-	-	-
K 40/25	JC	-	38 x 38 x 5	38 x 38 x 5	38 x 38 x 5	-	-	-	-
W 50/30	JB	-	50 x 50 x 6	50 x 50 x 6	50 x 50 x 6	50 x 50 x 6	-	-	-
K 50/30	JB	-	50 x 50 x 6	50 x 50 x 6	50 x 50 x 6	50 x 50 x 6	-	-	-
W 53/34	JB	-	50 x 50 x 6	50 x 50 x 6	50 x 50 x 6	50 x 50 x 6	-	-	-
K 53/34	JB	-	50 x 50 x 6	50 x 50 x 6	50 x 50 x 6	50 x 50 x 6	-	-	-
W 55/42	JB ²⁾	-	-	-	50 x 50 x 6	50 x 50 x 6	50 x 50 x 6	-	-
W 72/48	JA	-	-	-	-	70 x 70 x 8	70 x 70 x 8	70 x 70 x 8	70 x 70 x 8
K 72/48	JA	-	-	-	-	70 x 70 x 8	70 x 70 x 8	70 x 70 x 8	70 x 70 x 8

²⁾ JB M 24 is identical to JE M 24

Prestressed Bolted Joints and Tightening Torque

Prestressing Forces of T-Bolts

In connection technology, for the applications

- **Suspended direct and stand-off installation**
- **Stress in the channel longitudinal direction**

it is important to prestress the bolted connections in order to prevent undesired loosening or slippage of the bolted connections. Higher-strength bolts (8.8) are not absolutely necessary for this purpose. Grade 4.6 and A4-50 bolts are also adequate if the following points are taking into consideration:

- In the short term, a force arising from prestressing with tightening torque is normally higher than the external load.
- The applied prestressing force is dissipated down to about 30 % by relaxation.
- Bolts made of stainless steel exhibit higher friction than electro zinc plated or HDG bolts. Therefore, stainless steel bolts produce lower prestressing forces.

- JORDAHL® bolts are supplied ready for installation. They should not be additionally oiled or treated with lubricants before the tightening torque is applied.
- The bolted joint may be prestressed only when there is **steel to steel** contact.

If the channel is set back behind the concrete surface, then the connection must be shimmed by means of a suitable washer (see page 11).

If this is not followed and the attached part is prestressed against the concrete surface, it leads to residual stresses in the component. These can cause cracks or splitting of the concrete component.

Suspended Direct and Stand-Off Installation

For these applications, cold formed and hot rolled profiles can be used. In order to prestress a bolted joint with electro-galvanized (gv) bolts or stainless steel bolts, we recommend using the tightening torques according to page 14.

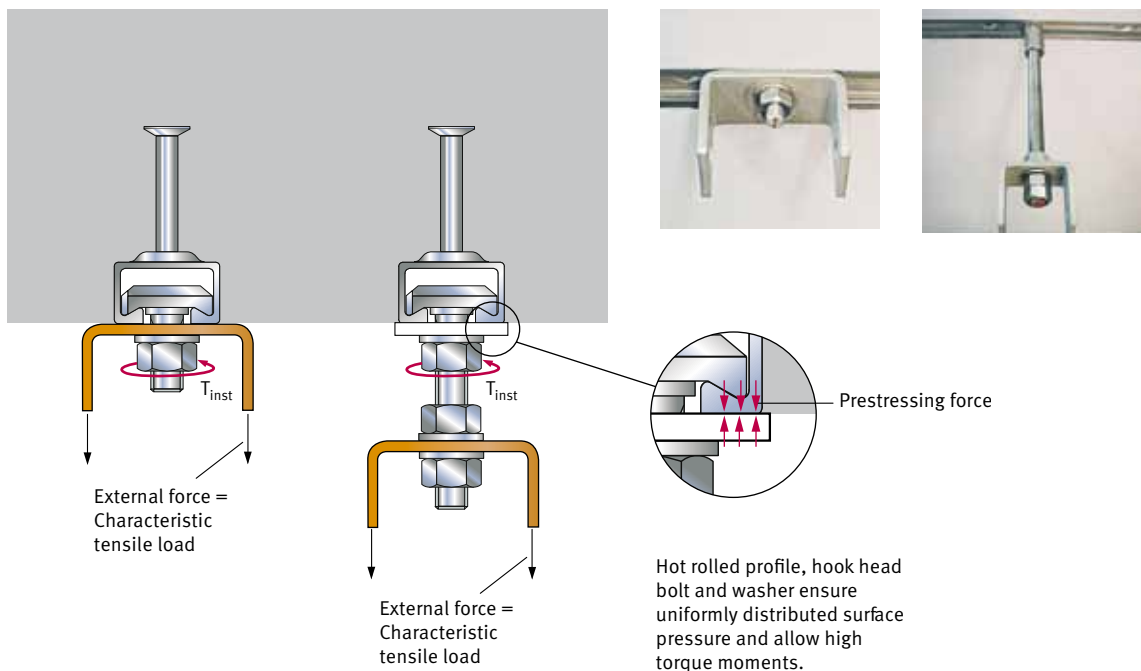

The relationship between prestressing force and tightening torque can be seen from the graphs below. The prestressing forces vary strongly with the friction in the thread between the nut and the bolt. Low friction causes high pre-load, typical for hot-dip galvanized bolts with lubricated nuts.

Friction is increased for clean galvanized (medium) and stainless steel (high) nuts and bolts. The recommended installation torque may be increased by 30 % without danger of reaching the yield strength of the bolts.

Relationship between Prestressing Force and Installation Torque for:

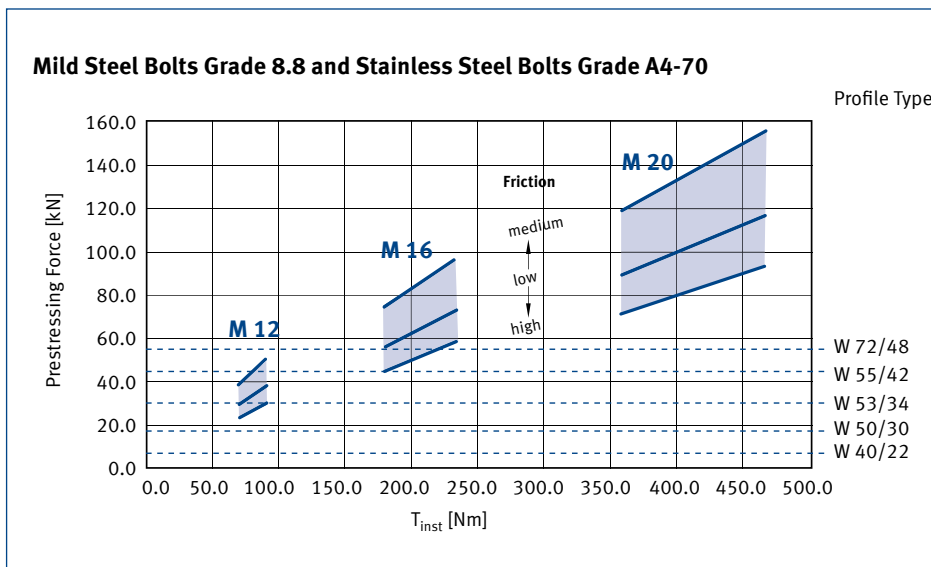
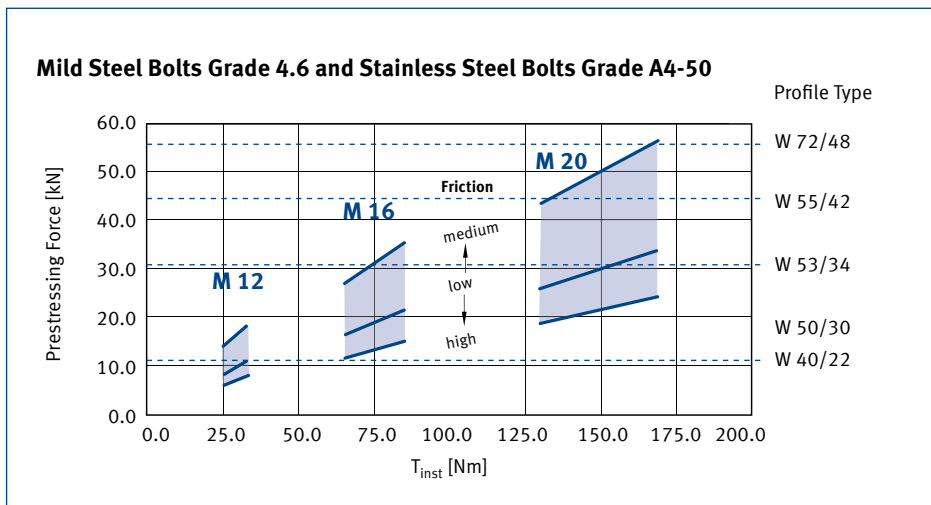

Recommended Tightening Torque T_{inst}

General

If the connecting plate is braced to the concrete or to the anchor channel respectively braced to concrete and anchor channel, the torque moments according to the following table shall be applied.

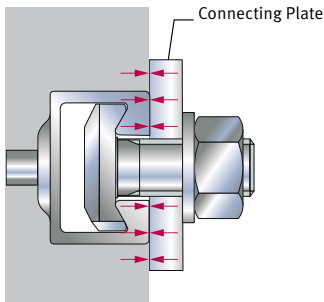

Steel-Steel-Contact

If the connecting plate is braced to the anchor channel by suitable washer, the torque moments according to the following table shall be applied. For bolts grade 8.8 and A4-70 higher torque moments may be applied.

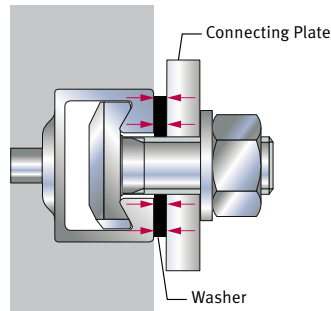

Profile and Type of Bolt	Bolt Ø	Torque Moment T_{inst}		
		General	Steel-Steel-Contact	
		4.6 & 8.8 A4-50 A4-70 F4-70	4.6 A4-50	8.8 A4-70 F4-70
	[mm]	[Nm]	[Nm]	[Nm]
K 28/15 JD	M 6	–	3	–
	M 8	8	8	20
	M 10	13	15	40
	M 12	15	25	70
K 38/17 JH	M 10	15	15	40
	M 12	25	25	70
	M 16	40	65	180
W 40/22 K 40/25 JC	M 10	15	15	40
	M 12	25	25	70
	M 16	45	65	180
W 50/30 K 50/30 JB	M 10	15	15	40
	M 12	25	25	70
	M 16	60	65	180
	M 20	75	130	360
W 53/34 K 53/34 JB	M 10	15	15	40
	M 12	25	25	70
	M 16	60	65	180
	M 20	120	130	360
W 55/42 JB	M 10	15	15	40
	M 12	25	25	70
	M 16	60	65	180
	M 20	120	130	360
	M 24	200	230	620
W 72/48 K 72/48 JA	M 20	120	130	360
	M 24	200	230	620
	M 27	300	340	900
	M 30	380	460	1200

Category of Corrosion: ISO 12944-2	Profile	Anchor	Bolt, Nut, Washer	Intended Use
C1 harmless	mill finish	mill finish	mill finish without corrosion protection	Only possible when all the connection elements are protected, depending on the ambient conditions, by a minimum concrete cover according to Eurocode EC2.
C2 low	hot-dip galvanized (HDG), layer > 50 µm	hot-dip galvanized (HDG), layer > 50 µm	electro zinc plated (ZP) layer > 5 µm	Concrete components in interior rooms, for example dwellings, offices, schools, hospitals, retail premises – with the exception of wet rooms.
C3 medium	hot-dip galvanized (HDG), layer > 50 µm	hot-dip galvanized (HDG), layer > 50 µm	hot-dip galvanized (HDG), layer > 50 µm	Concrete components in interior rooms with normal atmospheric humidity (including kitchens, bathrooms and washrooms in dwellings) – with the exception of permanent moisture.
C4 high	stainless steel 1.4401/1.4404/ 1.4571 (A4) 1.4362 (L4)	stainless steel 1.4401/1.4404/ 1.4571 (A4) ¹⁾ 1.4362 (L4) ¹⁾ Weld-on anchor mill finish ²⁾	stainless steel 1.4401/1.4404/ 1.4571 (A4-50, A4-70) 1.4362 (L4-70)	Applications with medium corrosion resistance, for example in wet rooms, exposed to weather, industrial atmosphere, close to the ocean and inaccessible areas.
C5 severe	stainless steel 1.4462 (F4) ³⁾ 1.4529/ 1.4547 (HC)	stainless steel 1.4462 (F4) 1.4529 (HC) Weld-on anchor mill finish ²⁾	stainless steel 1.4462 (F4-70) ³⁾ 1.4529/ 1.4547 (HC-50, HC-70)	Applications with severe corrosion resistance and high corrosion loading by chlorides and sulphur dioxide (including concentration of the pollutants, for example in the case of components in saltwater and road tunnels).

¹⁾ JORDAHL® stainless steel anchor channels with round anchors:
The anchor channel types JTA K 28/15 to W 50/30 are produced as standard with stainless steel round anchors. These anchor channels are not subject to any restriction with respect to the concrete cover.

The anchor channel types JTA W 72/48, K 72/48 and W 53/34, K 53/34 can be produced with stainless steel round anchors or welded-on mild steel I-anchors. The static and dynamic properties of the round anchors or welded I-anchors are the same as each other.

²⁾ JORDAHL® stainless steel anchor channels with mill finish weld-on anchors: The following concrete cover *c* must be used for the corrosion protection of the welded anchors.

W 53/34 K 53/34 [mm]	W 72/48 K 72/48 [mm]
40	60

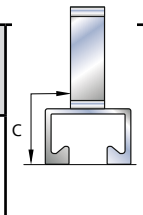

³⁾ Description of F4 also applies to FA (1.4462)

JORDAHL® Expert Software

JORDAHL® Expert is an intuitively user friendly design software available for the efficient design of JTA-CE anchor channels.

The program is based on the European Technical Approval (ETA-09/0338) and the design specifications for anchor channels CEN/TS 1992-4-3.

The software can be downloaded free-of-charge at www.jordahl.de.

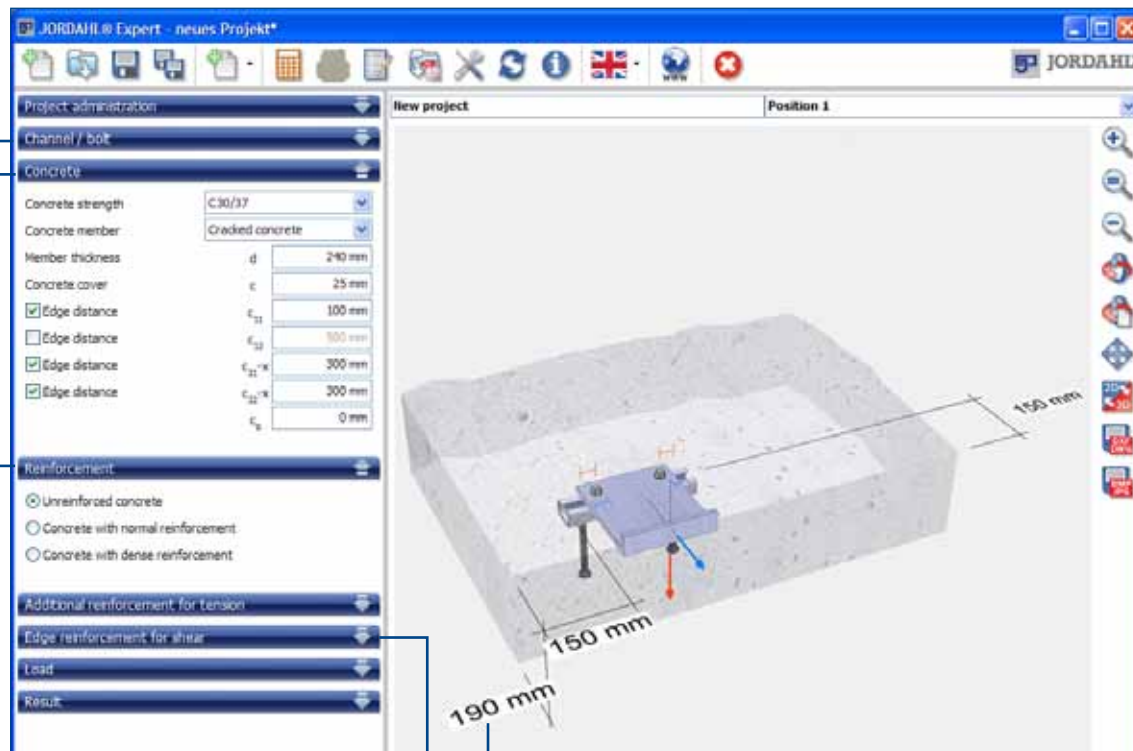

→ Anchors / Bolt

- Length of the channel
- Hot-dip galvanized or stainless steel material
- Clearance assembly

→ Concrete

- Concrete quality
- Slab thickness
- Edge Distances
- Concrete cover

→ Constructive Reinforcement

- Normal or non-reinforced concrete
- Dense reinforcement

→ Graphics

The current input parameters are displayed interactively in clear 3D graphics. Using the mouse the view can be rotated, displaced and zoomed intuitively.

→ Edge Reinforcement

With the aid of JORDAHL® Expert it is possible to take into account the existing edge frame or specifically positioned reinforcement when designing the anchoring:





DXF/DWG export of the graphics into your CAD system



Optional switchover to a 2D view

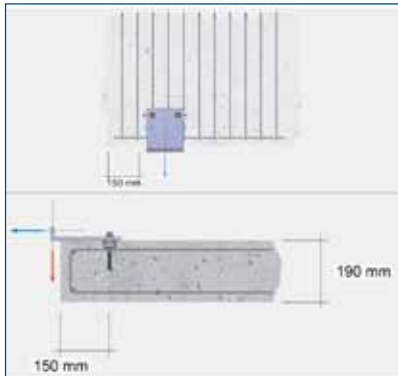

Loading

- Single loads
- Pair loads
- Regular loads
- User-defined

If no displacement range is specified, the most unfavourable load position on the channel is determined internally in the programme. The load or load spectrum is displaced as a moving load over the total available channel length.

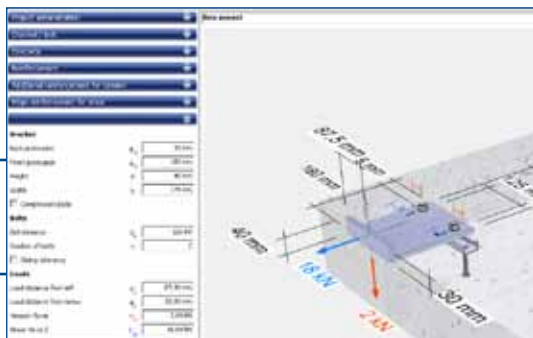

Load input with design loads and optional bracket dimensions

Dynamic Loading

In addition to static loads, dynamic loads can be assessed according to the load range.

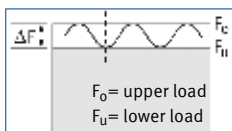

Results

In the result review there is a short summary of the results for all of the potential channel sizes.

Designation	Maximum utilization
JTA W 80/22-0250-2A-hdg CE	92,87 %
JTA W 30/30-0250-2A-hdg CE	66,52 %
JTA W 53/34-0250-2A-hdg CE	82,57 %

Detailed Results

The maximum usage and proof details are in the monitor display

Designation	Maximum utilization
JTA W 80/22-0250-2A-hdg CE	92,87 %
Anchor 1	92,87 %
Stem - Compression reinforcement and stirrups	95,37 %
Stem - Tied Stirrups	11,75 %
Stem - Concrete core stress	3,08 %
Stem - Top flange anchor	96,98 %
Stem - Top-Flange	41,37 %
Stem - Reinforcement in Flange	92,87 %
Stem - Reinforcement in Stem	92,87 %
Stem - Reinforcement in Stem	92,87 %
Stem - Reinforcement in Stem	92,87 %
Stem - Reinforcement in Stem	92,87 %
Anchor 2	49,05 %
Stem - Compression reinforcement and stirrups	95,37 %
Stem - Tied Stirrups	11,75 %
Stem - Concrete core stress	3,08 %
Stem - Top flange anchor	96,98 %
Stem - Top-Flange	41,37 %
Stem - Reinforcement in Flange	92,87 %
Stem - Reinforcement in Stem	92,87 %
Stem - Reinforcement in Stem	92,87 %
Stem - Reinforcement in Stem	92,87 %

Print-out of the Results

Comprehensive and clearly arranged print-out of the design with all data relevant to the proof.



Safety of Design

for Fastenings in Concrete –

Based on CEN/TS 1992-4-3: Anchor Channels

With the European countries officially introducing the CEN/TS 1992-4-3¹⁾ standard for anchor channels, a completely new developed design concept is now available to calculate the strength of anchor channels cast in concrete. This concept is based on the European partial safety design and the European Technical Approval for JORDAHL® anchor channels (ETA-09/0338). It generally leads to an improved utilisation of connections with JORDAHL® anchor channels and offers more flexibility in the design. The engineering-design approach generally allows a higher capacity with JORDAHL® anchor channels and allows greater flexibility in design.

The following individual conditions can be taken into account for the design of JTA anchor channels:

- Edge Distance
- Length of channel
- Load positioning along the channel
- Concrete Strength
- Additional reinforcement
- Thickness of concrete member

The consideration of the above mentioned influences allows tailor-made designs for the specific needs of each project. The key-benefit of this design concept is to reach the optimum of economic and technical efficiency.

This state-of-the-art design for anchorage in concrete is now available as JORDAHL® EXPERT software.

¹⁾ CEN/TS 1992-4 is a pre-standard, which should be incorporated in the Eurocode Series as EC2-4. An abbreviated version including the paragraphs crucial for the design of the anchor channels can be downloaded from the internet at www.vbbf.de.

EUROCODE Design Concept: $F_{Ed} \leq F_{Rd}$

Today's building structures are usually designed according to the concept with partial safety factors.

The concept is published in the Eurocodes (EC) and was adopted by all national standardization organizations in Europe.

The design in accordance with EC2 (concrete) or EC3 (steel) takes place at the design level, i.e. the design loads F_{Ed} are compared with the design resistances F_{Rd} .

The design method according to the Eurocode concept is as follows: The design loads F_{Ed} are loads factored with various partial factors depending on the load characteristic (e.g. dead or live load) and probability of simultaneous occurrence (load combinations).

The design loads are compared with the design resistance $F_{Rd} = F_{Rk} / \gamma_M$ where F_{Rk} is the characteristic resistance and γ_M is a specific partial factor for the material property (e.g. concrete – $\gamma_{Mc} = 1.5$,
rebar steel – $\gamma_{Ms,re} = 1.15$)

In general the proof according to this safety concept is stated as:

$$\frac{F_{Ed}}{F_{Rd}} \leq 1 \quad \text{or} \quad F_{Ed} \leq F_{Rd}$$

If this proof is fulfilled, the design resistance is therefore larger than the design effect and the state of load-bearing safety is within limits.

Determination of the design effects and resistances requires more effort than the simplified and uneconomical design with permitted loads and stresses.

For the planner the process opens up the possibility in the design of a load bearing structure to take into account more realistically the various influences of the loads and the different properties of the material. With this design approach, therefore, a constant and reliable level of safety can be achieved.

With today's knowledge of potential failure modes it is possible to achieve an efficient and economic design. However, it is imperative that all data for such a detailed comparison is available.

The resistances of JORDAHL® anchor channels published in this catalogue are based on today's knowledge of anchoring in concrete as stated in CEN/TS 1992-4 and the European Technical Approval for JORDAHL® anchor channels. This Approval is based on numerous tests, statistical and numerical analysis and the Eurocode design concept.

The approval from the Deutsches Institut für Bautechnik (DIBt) [German Institute for Structural Engineering], applicable Europe-wide, is based on numerous tests as well as statistical and numerical analyses and the Eurocode design concept.

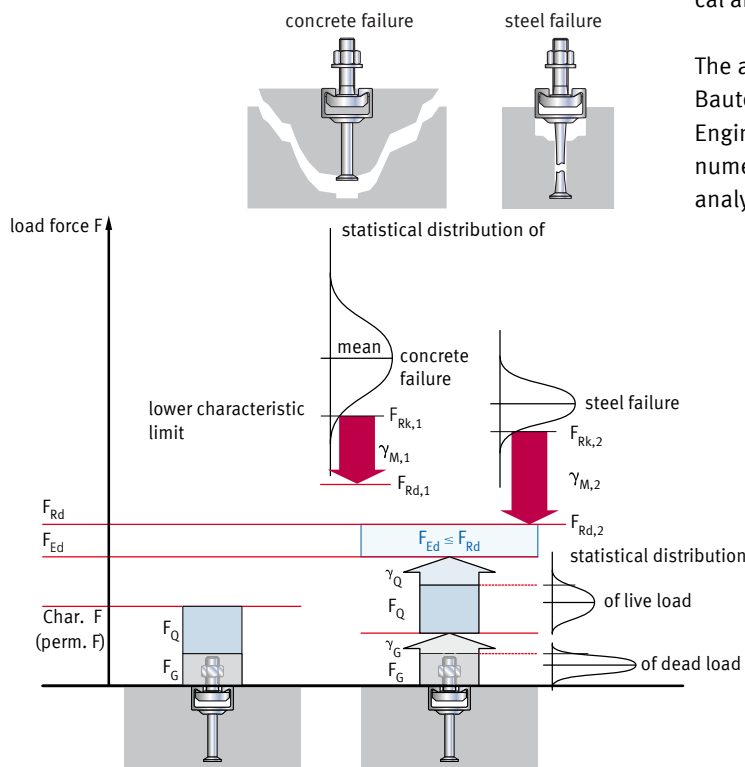

- $F_{Rk,i}$ = characteristic resistance for material
- $\gamma_{M,i}$ = are the individual partial safety factors for material i
- F_{Rd} = design resistance
 $F_{Rd} = \min(F_{RD,1}, F_{RD,2}, F_{RD,i})$
 $F_{RD,i} = F_{Rk,i} / \gamma_{M,i}$
- F_{Ed} = design load
 $F_{Ed} = \gamma_G \times F_G + \gamma_Q \times F_Q$
- F_Q = unfactored life load
- γ_Q = load safety factor for life load
- F_G = unfactored dead load
- γ_G = load factor for dead load

Safety Factors in conjunction with CEN/TS 1992 - Eurocode 2

All design resistances published in this brochure are based on the partial safety concept and include the following partial safety factors:

	Factor	to find in
Steel	γ_M	CEN/TS 1992-4-1
Connection anchor and channel $\gamma_{M,ca}$	1.8	4.4.3.1.1
Local flexure of channel lip $\gamma_{M,sl}$	1.8	4.4.3.1.1
Supplementary reinforcement $\gamma_{M,rs}$	1.15	4.4.3.1.1
Concrete, unreinforced		
Pull-out γ_{Mp}	1.5	4.4.3.1.3
Concrete cone failure γ_{Mc}	1.5	4.4.3.1.2
Concrete edge failure γ_{Mc}	1.5	4.4.3.1.2
Concrete reinforced		
<i>Tension:</i> Anchorage failure	1.5	4.4.3.1.2
<i>Shear:</i> Anchorage failure	1.5	4.4.3.1.2

For partial load safety-factors and combinations we recommend to use EN-1990 (Eurocode 0), Annex A.

Applications



Curtain Wall



Precast Concrete Elements



Brickwork Support



Overhead Crane Rails



Stadium Seats



Attachment of Cable Support Systems



Industrial Machine Foundations



Water Pipelines and other Supports



Elevators



Overhead Electrical Lines

Installation

Efficient, Easy and Fast

JORDAHL® supplies anchor channels in all desired lengths. To avoid fresh concrete from flowing into the profile, JORDAHL® anchor channels are filled with either polystyrene (PS) or polyethylene (PE) foam. Both types can be removed easily.

Connecting

JORDAHL® anchor channels are installed according to the reinforcement/formwork drawings. To prevent displacement during concrete pouring, the channels are held in place:

- on wooden formwork by nails through the nail holes in the back of the profile, or by lateral bonding with hot melt adhesives
- on steel formwork by bonding with hot melt adhesives, or by bolting on with JORDAHL-T-bolts, or with magnets
- on the surface of a concrete slab by wiring the anchors to reinforcement bars or, if required, by means of special spacers spot welded to the anchors



Concrete

Concrete is poured into the formwork.



Removal of Foam Filler

After the removal of the formwork the foam filler can be easily removed by means of a hammer or other tools.



Mounting Connections

JORDAHL® T-bolts can now be inserted into the anchor channel slot at any desired point and, following 90° rotation, can be fixed by tightening with the appropriate torque. The slot on the bottom of the bolt must be transverse in relation to the channel direction.





JORDAHL®

Subsidiaries

Austria

www.jordahl-group.com/at

Czech Republic

www.jordahl-group.com/cz

China

www.jordahl-group.com/cn

Denmark

www.jordahl-group.com/dk

Great Britain

www.jordahl-group.com/uk

Hong Kong

www.jordahl-group.com/hk

India

www.jordahl-group.com/in

Poland

www.jordahl-group.com/pl

Romania

www.jordahl-group.com/ro

Singapore

www.jordahl-group.com/sg

Spain

www.jordahl-group.com/es

Switzerland

www.jordahl-group.com/ch

We have distributors
in the following countries:

- Belgium
- Croatia
- Estonia
- Finland
- France
- Greece
- Hungary
- Italy
- Latvia
- Lithuania
- Netherlands
- Norway
- Russia
- Saudi Arabia
- Sweden
- U.A.E.
- USA
- Vietnam

Further information is available on the
website [www.jordahl-group.com/home/
enterprise/distribution/international](http://www.jordahl-group.com/home/enterprise/distribution/international)

condition 05/2011 / 1st edition 05-2011 / HH / 0.000

Deutsche Kahneisen Gesellschaft mbH

Head office:
Nobelstrasse 51
12057 Berlin
Germany

Production Plant Trebbin:
Industriestrasse 5
14959 Trebbin
Germany

info@jordahl.de
www.jordahl.de