



for better solutions...



Shear dowel

Shear force transmission in expansion joints



Reliable expansion
joint dowelling in
concrete structural
elements

Reinforcement for a safe connection

Shear dowel HED

General

Single shear dowel HED – Expansion joint dowelling for concrete structural elements

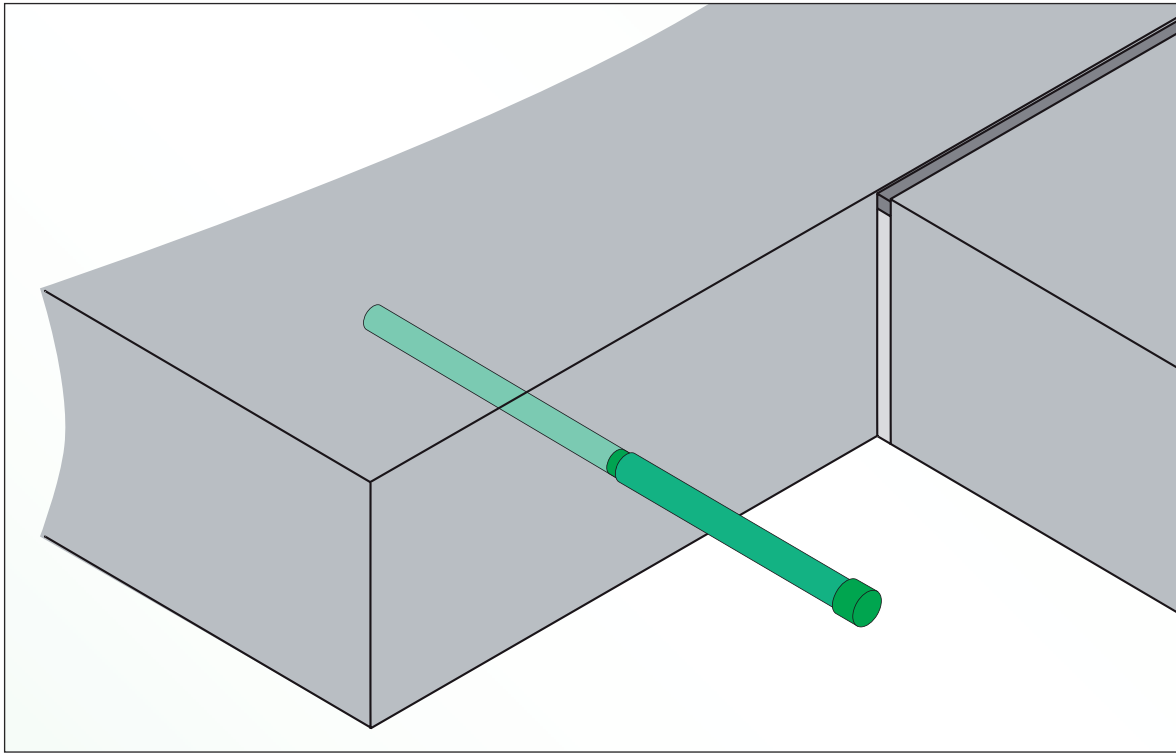

The product

Due to the use of these HED Type shear dowels, dowelling applications on expansion joints can be solved simply and reliably even where there are varying shear forces.

It guarantees a displacement of the structural element in the longitudinal axis of the rod up to a joint width of 50 mm.

All types are available with a special fire protection sleeve for classification according to F90.

Features

- Prevents component displacement in the area of the joint
- Simple, precise-fit assembly using shear dowel sleeves on the shuttering. A rip-proof film protects the sleeve from ingress of concrete
- There is no requirement to drill through the shuttering or supplementary drilling of the concrete.

Application area

Single Type HED shear dowels are used wherever shear forces are to be transferred through structural joints, e.g. expansion joints between concrete slabs, in floors and walls, for joints between supports and walls or between balconies and floors.

Shear dowel HED

Types and dimensions

for better solutions...



Types



Shear dowel HED-S + GS sleeves

- Motion in the longitudinal direction
- Transfer of the shear forces
- Stainless steel sliding sleeve

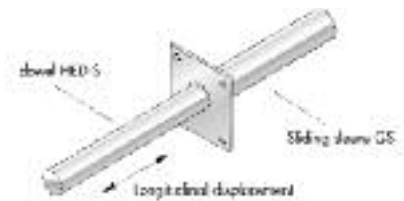

Shear dowel HED-S + GSQ sleeves

- Motion in the longitudinal and transverse direction
- Transfer of the shear forces
- Stainless steel sliding sleeve

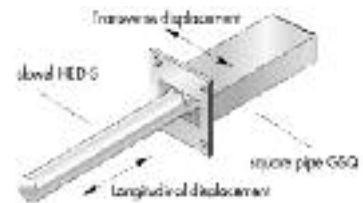

Shear dowel HED-S + GK sleeves

- Motion in the longitudinal direction
- Transfer of the shear forces
- Plastic sliding sleeve

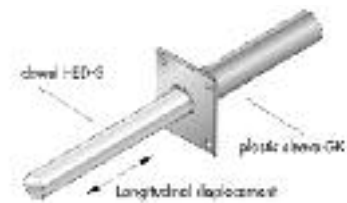

Shear dowel HED-P

- Motion in the longitudinal direction
- Transfer of the shear forces
- With plasticized spring element



Dimensions

Type [mm]	dowel element		Sleeves GS, GK		Sleeves GSQ		
	dowel \varnothing [mm]	dowel length l_D [mm]	sleeve length l_H [mm]	Nail plate B/H [mm]	sleeve length l_H [mm]	Nail plate B/H [mm]	max transverse displacement y [mm]
HED-S 20	20	300	160	70/70	180	80/80	± 11
HED-S 22	22	300	160	70/70	180	80/80	± 10
HED-S 25	25	300	160	70/70	180	80/80	± 14
HED-S 30	30	350	185	80/80	205	100/80	± 21

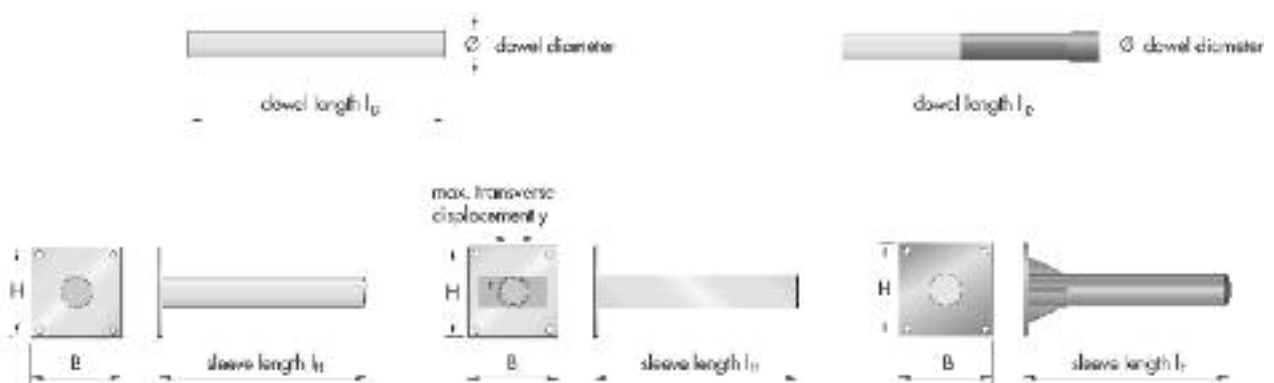

SHEAR DOWEL

Shear dowel HED

Dimensioning resistances

Dimensioning the resistances

The decisive resistance for dimensioning is the lesser value of the steel bearing capacity and concrete bearing capacity:

$$V_{Rd} = \min(V_{Rd,S}; V_{Rd,C})$$

The decisive resistance for the concrete bearing capacity is the lesser value of the verifications of concrete edge break and punching shear:

$$V_{Rd,C} = \min(V_{Rd,ce}; V_{Rd,ct})$$

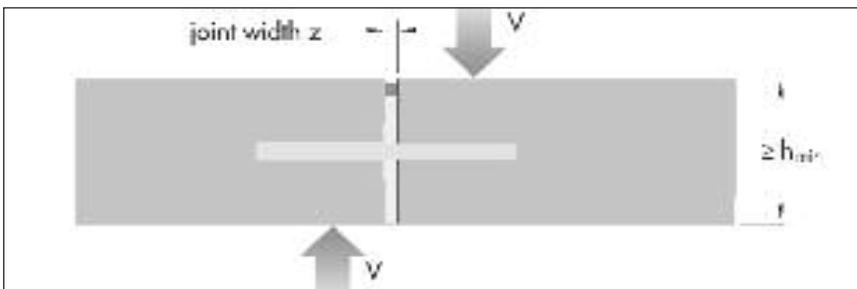

- $V_{Rd,S}$ Dimensioning resistance of the steel bearing capacity taking into account the friction forces ($f_{\mu} = 0,9$)
- $V_{Rd,C}$ Dimensioning resistance of the concrete bearing capacity taking into account the reinforcement
- $V_{Rd,ce}$ Dimensioning resistance of the concrete edge break according to the expert opinion of Prof. Eligehausen 2004
- $V_{Rd,ct}$ Dimensioning resistance to punching shear in accordance with DIN 1045-1

- f_{μ} 0,9 reduction factor for friction
- f_{yk} Yield point [N/mm²]
- f_{ck} Characteristic cylinder compressive strength of the concrete [N/mm²]
- z Joint width [mm]
- \varnothing dowel diameter [mm]
- W Moment of resistance [mm³]
- γ_{MS} Material safety factor for steel

Dimensioning resistances for concrete and steel bearing capacity in reinforced concrete

Type HED-S HED-P	Dimensioning resistances for steel bearing capacity $V_{Rd,S}$ [kN] taking the friction for the joint width z into account				Component thickness h [mm]	Rated resistances concrete load capacity* $V_{Rd,C}$ [kN]
	0 - 10 mm	11 - 20 mm	21 - 30 mm	31 - 40 mm		
20	14,3	9,5	7,1	5,7	≥ 160 ≥ 180	13,7 14,3
22	18,1	12,2	9,3	7,4	≥ 160 ≥ 180 ≥ 200 ≥ 220 ≥ 240	14,2 15,8 17,2 18,0 18,1
25	24,8	17,1	13,1	10,6	≥ 180 ≥ 200 ≥ 220 ≥ 240 ≥ 260	20,5 22,4 23,6 24,6 24,8
30	38,5	27,5	21,4	17,5	≥ 220 ≥ 240 ≥ 260 ≥ 280 ≥ 300 ≥ 320	29,2 31,5 33,7 35,8 38,0 38,5

* taking on-site reinforcement into account

** for the values highlighted in green the dimensioning resistance of the steel bearing capacity is reached taking the friction forces ($f_{\mu} = 0,9$) into account .

The determination of the dimensioning resistances for the steel bearing capacity according to Booklet 346, DafStb as follows:

$$V_{Rd,S} = f_{\mu} \cdot 1,25 \cdot (f_{yk} / \gamma_{MS}) \cdot W / (z + \varnothing/2)$$

Dimensioning resistances in non-reinforced concrete

Type HED-S HED-P	concrete	dowel \varnothing [mm]	min. construction element thickness h_{min} [mm]	Dimensioning resistances [kN] taking the resistance of the joint width z into account			
				0 - 10 mm	10 - 20 mm	20 - 30 mm	30 - 40 mm
20	$\geq C 20/25$	20	320	9,5	7,1	5,7	4,8
22		22	350	11,6	9,0	7,3	6,1
25		25	400	15,2	12,0	9,9	8,4
30		30	480	22,2	17,5	14,5	12,3

An edge spacing of $a_r \geq 8 \varnothing$ and a dowel spacing of $e \geq 16 \varnothing$ referred to the dowel axis must be maintained in all directions.

Dimensioning resistances according to Booklet 346

Steel bearing capacity:

$$V_{Rd,S} = f_u \cdot 1,25 \cdot (f_{yk} / \gamma_{MS}) \cdot W / (z + \varnothing)$$

Concrete bearing capacity:

$$V_{Rd,C} = 0,4 \cdot f_{ck} \cdot \varnothing^{2,1} / (333 + 12,2 \cdot z)$$

$$0,4 = (\alpha \cdot \gamma_{MS}) / 3$$

On-site reinforcement and minimum spacings

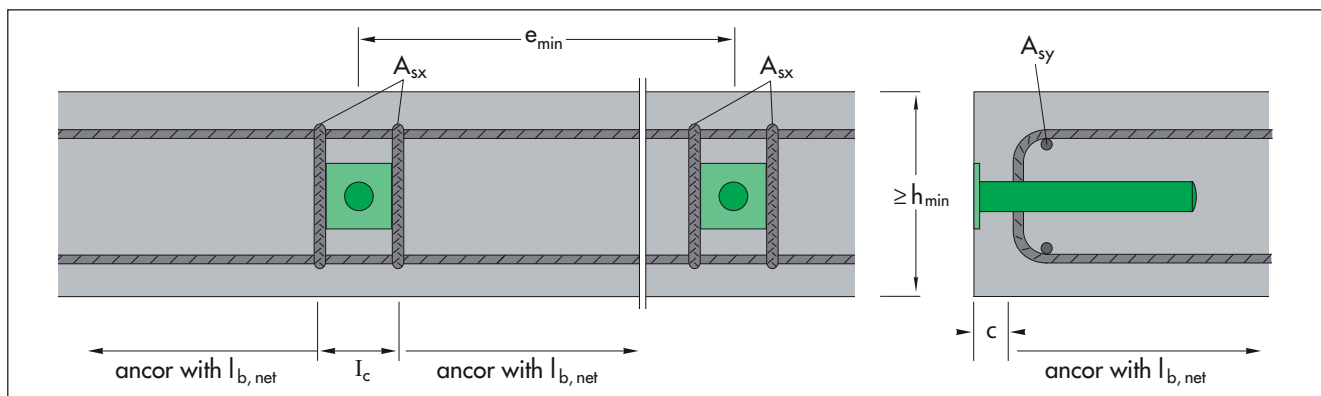

Type HED-S HED-P	Required dowel spacing e_{min} [mm]	Distance from edge a_r [mm]	Construction element thickness h_{min} [mm]	Stirrup spacing I_c [mm]	On-site reinforcement	
					A_{sx}	A_{sy}
20	310	155	160	60	2 \varnothing 10	2 \varnothing 10
22	350	175	160	60	2 \varnothing 10	2 \varnothing 10
25	410	205	180	70	2 \varnothing 12	2 \varnothing 12
30	560	280	220	90	2 \varnothing 14	2 \varnothing 14

e_{min} minimum spacing between axes of single dowels

a_r minimum distance from edge

h_{min} minimum construction element thickness

I_c Spacing of the first splice stirrup on the dowel

A_{sx} Splice stirrup

A_{sy} longitudinal reinforcement

Shear dowel HED

Fire protection

Fire protection sleeves

If there are technical fire protection requirements on the construction elements according to DIN 4102 Part 2, the shear dowels must be installed with fire protection sleeves.

In order to meet the classification F90 the unprotected dowel must be fitted with a fire protection sleeve in the joint.

In the event of a fire, the fire protection sleeve foams and completely fills the joint.

The sleeves are supplied in the following strengths:

- 20 for joint width 20-30 mm
- 40 for joint width 40 - 50 mm

The fire protection sleeves can be combined for larger joint widths.

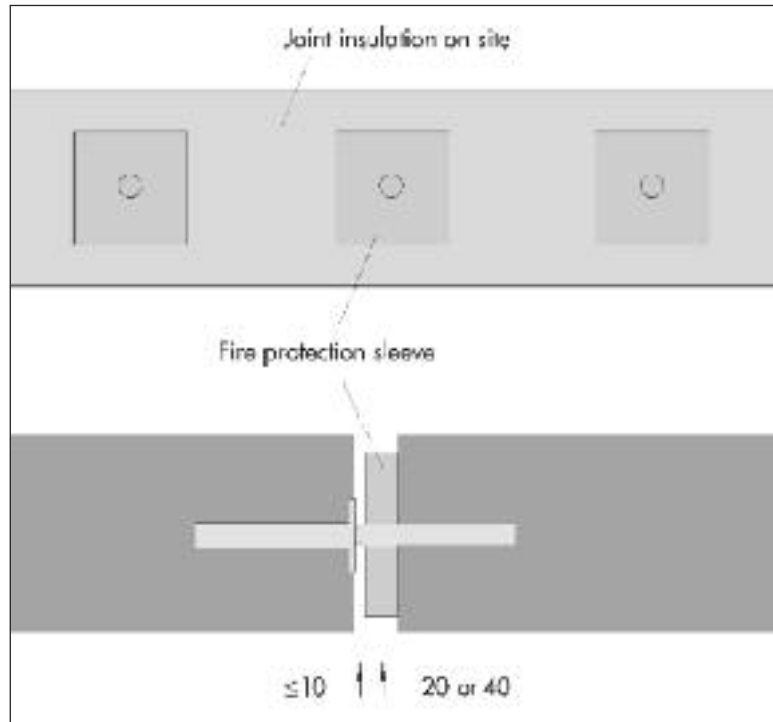

Dimensions of the fire protection sleeves

Fire protection sleeve for HED-S + GS/GK & HED-P

- 110 x 110 mm (b x h)
- hole diameter \varnothing 20 mm - \varnothing 30 mm
- strength 20 mm und 40 mm

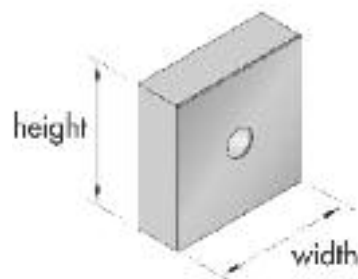

Fire protection sleeve for HED-S + GSQ

- 160 x 110 mm (b x h)
- hole diameter \varnothing 20 mm - \varnothing 30 mm
- strength 20 mm und 40 mm

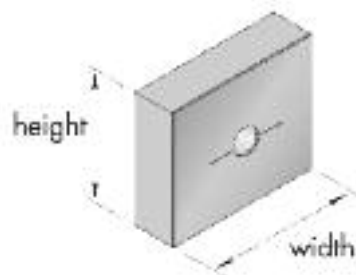

Installation instructions Schubdorn HED-S

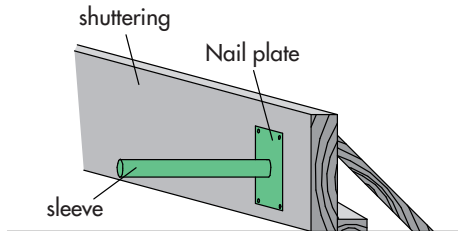

- Nail the sleeve on to the shuttering
- Do NOT remove protective sticker

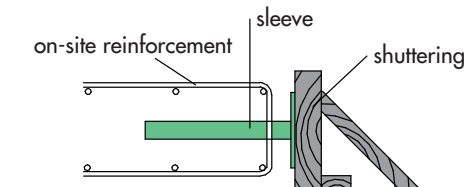

- Arrange the reinforcement in accordance with the reinforcement plan
- Concrete in the first section

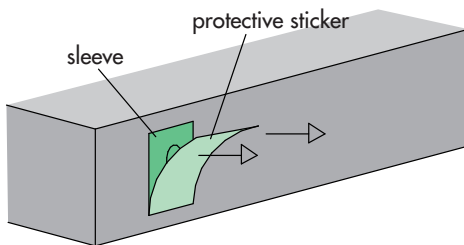

- Strip the shuttering
- Remove protective sticker

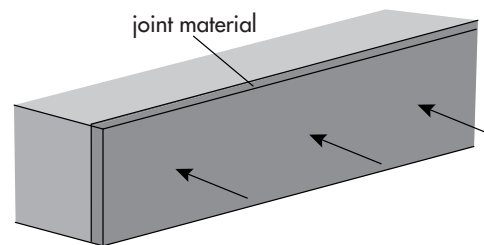

- Apply the joint material

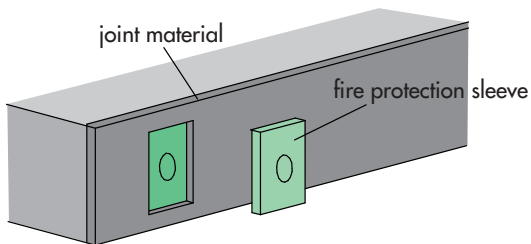

- Cut an aperture in the joint material
- Attach the fire protection sleeve

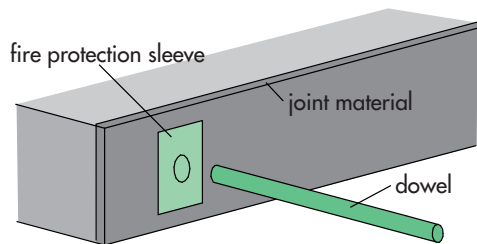

- Push the dowel into the sleeve

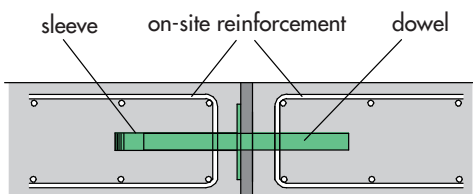

- Arrange the reinforcement in accordance with the reinforcement plan
- Concrete in the second section